

SA SELECTORIZED SERIES

SA054 - STANDING MULTI FLIGHT

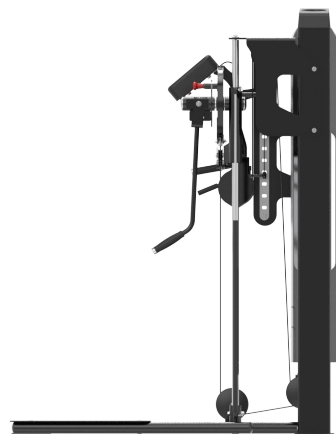
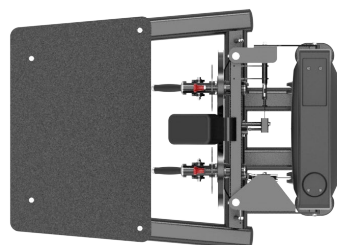

PRODUCT OVERVIEW

The SA054 is a multi-function selectorized upper-body training machine that combines standing chest fly and multi-angle fly movements. Designed to target the pectoralis major and deltoid muscles, it features a high-precision linear guide and a smooth pulley system to ensure stable motion paths and an exceptional training experience.

Equipped with 13 independently adjustable handles, the machine supports a wide range of fly movements—from horizontal chest fly to incline and decline angles—providing comprehensive muscle activation to suit various training goals and user preferences. The handles also feature self-adjusting forward/backward positioning to accommodate different arm lengths and stance widths, helping users find their ideal force application posture for maximum training efficiency.

The 14-level height adjustment system supports both upright and bent-over training positions, ensuring optimal alignment for users of all heights. This adjustment ensures that the motion trajectory aligns naturally with the shoulder joint's anatomical movement path, delivering a more comfortable and effective workout. A user-friendly headrest provides support during bent-over exercises, reducing lower back strain and minimizing compensatory body movement, allowing for more isolated and focused muscle engagement. Additionally, the one-handed adjustment mechanism enhances ease of use and training efficiency.

SPECIFICATIONS & KEY FEATURES

Specifications

Dimension	1415*1025*1815mm
Total Weight:	286kg
Weight Stack:	100kg
Max Weight Stack:	100kg

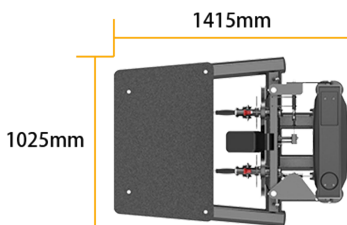
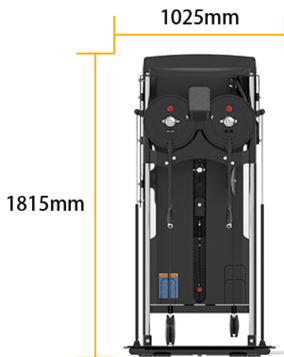
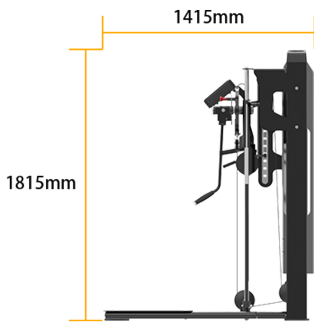

Product Features



Dual-Function Design

Supports both standing chest fly and multi-angle fly movements, expanding training options and space efficiency.

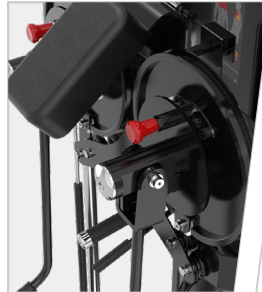

13-Level Independently Adjustable Handles

Accommodate various arm spans, joint paths, and stance widths, enabling precise targeting of upper-body muscles.

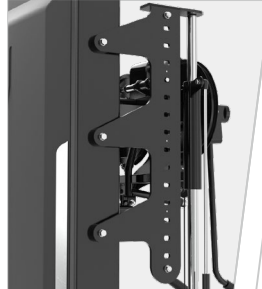

14-Level Height Adjustment System

Adapts to multiple training postures, including upright and bent-over, suitable for users of different heights and exercise trajectories.



One-Handed Smooth Adjustment Mechanism

Easy to operate, saving time and effort while enhancing the overall workout flow.



Ergonomic Head Support

Provides added stability during bent-over fly movements, reducing lumbar pressure and preventing compensatory motion for more focused muscle activation.